

PRESS FITTINGS FOR PEX-AL-PEX PIPES

INTERMEDIATE TEE FITTING

4031

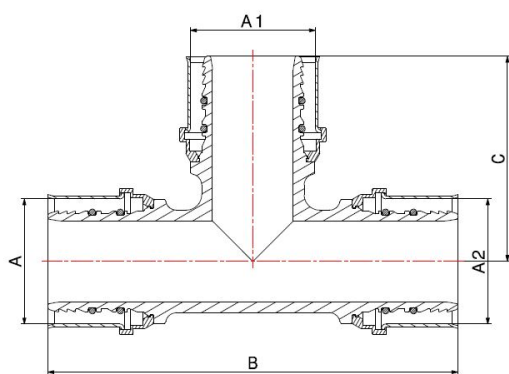
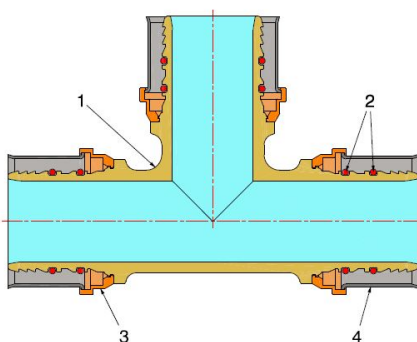

- Intermediate tee press fitting
- Maximum operating pressure 10 bar
- Temperature range min 0°C - max +95°C
- The jaws for the fittings pressing have to be **TH** profile.

Fitting suitable for distributing fluids that are generally non-corrosive, compatibly with the fitting materials. Heating, plumbing and industrial systems are the ideal fields of application, such as high and low temperature heating systems, air-conditioning and distribution of drinking water. The tightness is guaranteed by two EPDM PEROX O-Rings, particularly recommended with water-glycol solutions, with a maximum glycol presence of 50%. The steel sleeve pressing, carried out with electromechanical tools, ensures a perfect and indivisible crimping to the pipe as well as an excellent resistance to external stress.

ACS

COMPONENTS

POS.	PART NAME	N°	MATERIAL
1	Fitting	1	CW617N UNI-EN 12165
2	O-Ring	6	EPDM Perox
3	Bushing holder	3	Plastic
4	Bushing	3	AISI 304 stainless steel

In sizes 26-32 there is no bush holder and the PTFE washer is inserted

DIMENSIONS

A	A1	A2	B	C
63	26	63	174	74
63	32	63	174	74
63	40	63	174	78
63	50	63	174	87
63	63	63	174	87
75	50	75	207	95
75	63	63	197	95
75	63	75	207	95
75	75	75	207	103

PACKAGING

	63 - 26 - 63	63 - 32 - 63	63 - 40 - 63	63 - 50 - 63	63 - 63 - 63	75 - 50 - 75	75 - 63 - 63	75 - 63 - 75	75 - 75 - 75
CODE	4031632663	4031633263	4031634063	4031635063	4031636363	4031755075	4031756363	4031756375	4031757575
PCS BAG	2	2	2	2	2	1	1	1	1
PCS CARTON	8	8	8	8	8	6	6	6	6