

PRESS FITTINGS FOR PEX-AL-PEX PIPES

# PRESS FITTINGS WITH PERFORATED FIXED PIPE BRACKET

4004

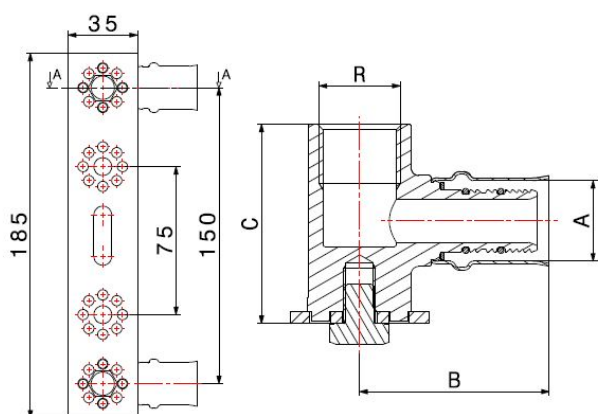
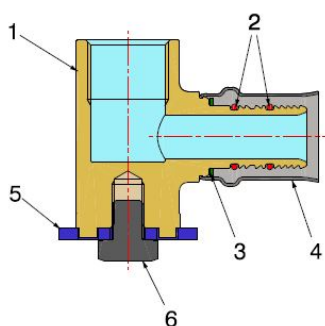
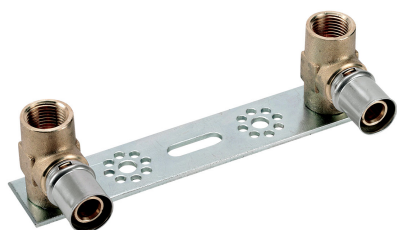

- Press fittings with perforated fixed pipe bracket
- Maximum operating pressure 10 bar
- Thread EN 10226-1
- Temperature range min 0°C - max +95°C
- The jaws for the fittings pressing have to be **TH** profile.

Fitting suitable for distributing fluids that are generally non-corrosive, compatibly with the fitting materials. Heating, plumbing and industrial systems are the ideal fields of application, such as high and low temperature heating systems, air-conditioning and distribution of drinking water. The tightness is guaranteed by two EPDM PEROX O-Rings, particularly recommended with water-glycol solutions, with a maximum glycol presence of 50%. The steel sleeve pressing, carried out with electromechanical tools, ensures a perfect and indivisible crimping to the pipe as well as an excellent resistance to external stress.

## ACS

### COMPONENTS

POS.	PART NAME	N°	MATERIAL
1	Fitting	2	CW617N UNI-EN 12165
2	O-Ring	4	EPDM Perox
3	Washer	2	PTFE
4	Bushing	2	AISI 304 stainless steel
5	Spacer pipe clip	1	Galvanised iron
6	M8 Screw	2	Galvanised iron

### DIMENSIONS

A	R	B	C
16	1/2"	48	51,5
20	1/2"	48	51,5

### PACKAGING

	16 - 1/2"	20 - 1/2"
CODE	40041604	40042004
PCS BAG	-	-
PCS CARTON	25	25