

PRESS FITTINGS FOR PEX-AL-PEX PIPES

FEMALE FLANGED ELBOW FITTING

4054

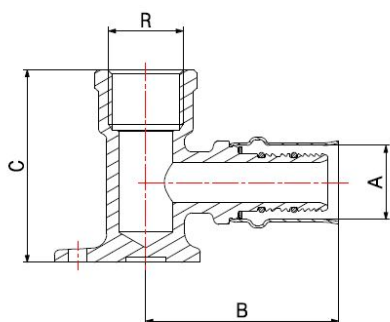
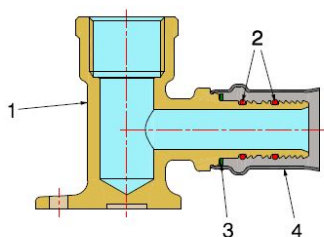

- Female flanged elbow press fitting
- Maximum operating pressure 10 bar
- Thread EN 10226-1
- Temperature range min 0°C – max +95°C
- The jaws for the fittings pressing have to be **TH** profile.

Fitting suitable for distributing fluids that are generally non-corrosive, compatibly with the fitting materials. Heating, plumbing and industrial systems are the ideal fields of application, such as high and low temperature heating systems, air-conditioning and distribution of drinking water. The tightness is guaranteed by two EPDM PEROX O-Rings, particularly recommended with water-glycol solutions, with a maximum glycol presence of 50%. The steel sleeve pressing, carried out with electromechanical tools, ensures a perfect and indivisible crimping to the pipe as well as an excellent resistance to external stress.

ACS

COMPONENTS

| POS. | PART NAME | N° | MATERIAL |
|------|-----------|----|--------------------------|
| 1 | Fitting | 1 | CW617N UNI-EN 12165 |
| 2 | O-Ring | 2 | EPDM Perox |
| 3 | Washer | 1 | PTFE |
| 4 | Bushing | 1 | AISI 304 stainless steel |

DIMENSIONS

| A | R | B | C |
|----|------|----|----|
| 16 | 1/2" | 53 | 53 |
| 18 | 1/2" | 53 | 53 |
| 20 | 1/2" | 53 | 53 |
| 20 | 3/4" | 53 | 55 |

PACKAGING

| | 16 - 1/2" | 18 - 1/2" | 20 - 1/2" | 20 - 3/4" |
|-------------|-----------------|-----------------|-----------------|-----------------|
| CODE | 40541604 | 40541804 | 40542004 | 40542006 |
| PCS BAG | 5 | 5 | 5 | 5 |
| PCS CARTON | 80 | 60 | 60 | 60 |