

WATER BALL VALVES

**MISSOURI FROM 2.1/2" TO 4"**

795102

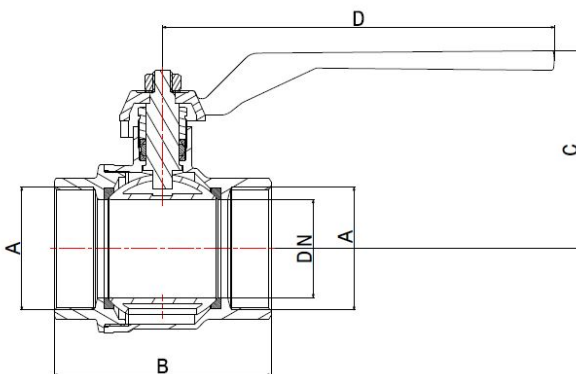
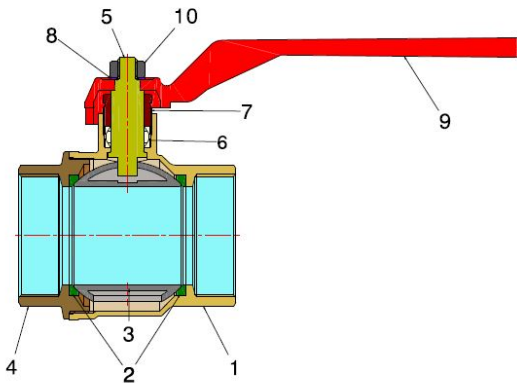
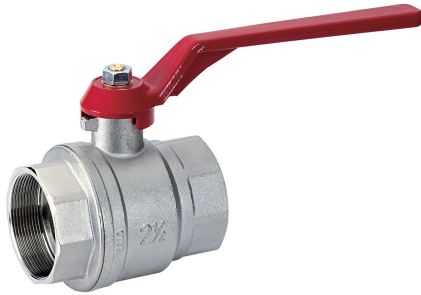

- F/F water ball valve with gland packing and aluminium lever
- Thread ISO 228
- Temperature range min -10°C - max +95°C

Valve suitable for distributing and interrupting liquids that are generally non-corrosive, compatibly with the valve materials. Plumbing, heating, industrial and agricultural sectors are the ideal fields of application. It's a standard bore valve and the ball seal is guaranteed by two PTFE seats.

The operating mechanism seal features two PTFE sealing rings with adjustable gland, internally installed stem and anti-ejection system. It is advisable to carry out a complete maneuver cycle at least once every three months in order to prevent limescale deposits that could compromise the valve functioning.



**COMPONENTS**

POS.	PART NAME	N°	MATERIAL
1	Body	1	CW617N UNI-EN 12165 nickel-plated
2	Seal	2	PTFE
3	Ball	1	CW617N UNI-EN 12165 chrome-plated
4	End connection	1	CW617N UNI-EN 12165 nickel-plated
5	Stem	1	CW617N UNI-EN 12164
6	Gland packing	3	PTFE
7	Gland	1	CW614 UNI-EN 12164
9	Washer	1	CW508L UNI-EN 1652
10	Lever	1	Lacquered aluminium
11	Nut	1	Galvanised iron

**DIMENSIONS**

DN	A	B	C	D	PN
65	2.1/2"	132	109	240	20
80	3"	167	127	240	20
100	4"	200	160	240	20

**PACKAGING**

	2.1/2"	3"	4"
<b>CODE</b>	<b>79510215</b>	<b>79510217</b>	<b>79510219</b>
PCS BOX	-	-	-
PCS CARTON	10	5	2