

BOILER DRAIN VALVES

BOILER DRAIN VALVE

776201



- M/F boiler drain valve with iron lever
- Finishing nickel-plated
- Thread ISO 228
- Temperature range min-10°C - max +120°C



Valve suitable for interrupting fluids that are generally non-corrosive, compatibly with the valve materials.

Plumbing and heating systems are the ideal fields of application, where this valve is used to unload heat transfer fluids from the heating system.

It's a reduced bore valve and the ball seal is guaranteed by two PTFE seats.

The operating mechanism seal features two O-Rings with an internally installed stem and anti-ejection system.

It is advisable to carry out a complete maneuver cycle at least once every three months in order to prevent limescale deposits that could compromise the valve functioning.

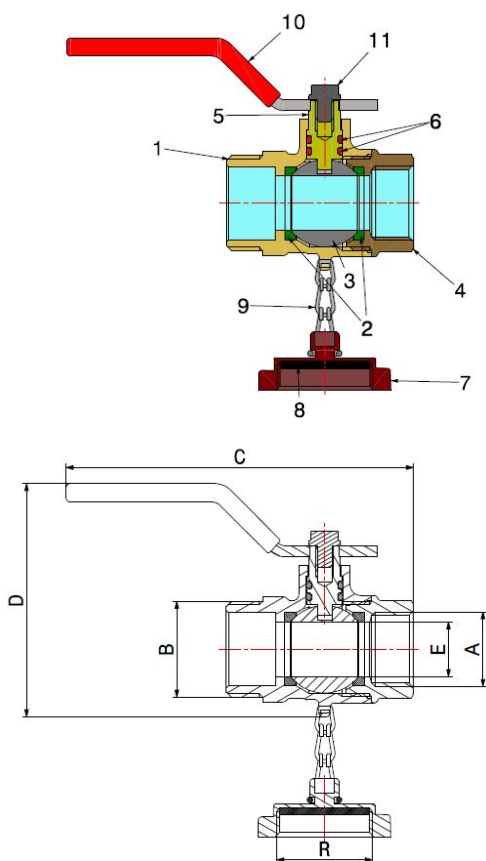

COMPONENTS

POS.	PART NAME	N°	MATERIAL
1	Body	1	CW617N UNI-EN 12165 nickel-plated
2	Seal	2	PTFE
3	Ball	1	CW617N UNI-EN 12164 chrome-plated
4	End connection	1	CW617N UNI-EN 12165 nickel-plated
5	Stem	1	CW617N UNI-EN 12164
6	O-Ring	2	EPDM 70 Perox
7	Plug	1	CW617N UNI-EN 12165 nickel-plated
8	Gasket	1	SBR
9	Chain	1	Iron
10	Lever	1	Galvanised iron and PVC coated
11	Screw	1	Galvanised iron

DIMENSIONS

DN	A	B	C	D	E	R	PN
15	1/2"	3/4"	51	46	15	3/4"	40

PACKAGING

CODE	77620104R
PCS BOX	10
PCS CARTON	100